



Volvo Construction Equipment

# A25G, A30G

VOLVO ARTICULATED HAULERS 24-28t 320-360hp



# A passion for performance.

At Volvo Construction Equipment, we're not just coming along for the ride. Developing products and services that raise productivity – we are confident we can lower costs and increase profits for industry experts. Part of the Volvo Group, we are passionate about innovative solutions to help you work smarter – not harder.

## Helping you to do more.

Doing more with less is a trademark of Volvo Construction Equipment. High productivity has long been married to low energy consumption, ease of use and durability. When it comes to lowering life-cycle costs, Volvo is in a class of its own.

## Designed to fit your needs.

There is a lot riding on creating solutions that are suited to the particular needs of different industry applications. Innovation often involves high technology – but it doesn't always have to. Some of our best ideas have been simple, based on a clear and deep understanding of our customers' working lives.



## You learn a lot in 180 years.

Over the years, Volvo has advanced solutions that have revolutionized the use of construction equipment. No other name speaks Safety louder than Volvo. Protecting operators, those around them and minimizing our environmental impact are traditional values that continue to shape our product design philosophy.

## We're on your side.

We back the Volvo brand with the best people. Volvo is truly a global enterprise, one that is on standby to support customers quickly and efficiently – wherever they are.

## We have a passion for performance.



Volvo Trucks



Renault Trucks



Mack Trucks

UD Trucks

Volvo Buses



Volvo Construction Equipment

Volvo Penta

Volvo Financial Services



#### **Volvo drivetrain**

From the engine to the axles, the ideally-matched, all-Volvo drivetrain has been purpose built for articulated haulers ensuring perfect harmony and optimized performance. The Volvo design delivers high rimpull, low fuel consumption and superior reliability in heavy-duty applications.

# Superior hauling powered by Volvo.

In 1966 Volvo Construction Equipment invented the world's first articulated hauler. Today, Volvo is still the market leader. With state-of-the-art technology and innovative features, the new G-Series haulers maneuver, travel and dump the load in the most efficient and safe way. The A25G and A30G will increase your productivity on tough job sites.

## Volvo engine

Featuring advanced technology and built on decades of experience, the powerful, new Volvo engine meets the Stage IV/Tier 4f emission regulations and delivers the ultimate combination of high performance and low fuel consumption.

## Wet brakes on all axles

Oil-cooled, wet, multiple disc brakes on all three axles deliver industry-leading braking performance, low operating costs and ultimate durability – even on the muddiest and dustiest sites. The powerful and easy-to-operate retardation system controls downhill hauling speed using the wheel brakes and the Volvo Engine Brake (VEB).



## Automatic Traction Control (ATC) and differential locks

Volvo's unique design boasts 100% lockable, no-slip, no-wear differential locks in 6x4 and 6x6 drive combinations. ATC automatically activates the differential locks and selects the correct combination based on the ground conditions – ensuring optimal traction and mobility with reduced fuel consumption and tire wear. By locking all differentials, all wheels rotate at the same speed for maximum traction in tough terrain.

# Built to last.

Volvo's articulated haulers are in a league of their own. These robust, reliable machines excel in a variety of ground conditions – from deep mud to dusty haul roads – delivering durability you can count on. Experience outstanding machine control and precise, stable movement in Volvo's new G-Series articulated haulers.

## Hydro-mechanical steering

Unique, self-compensating, hydro-mechanical system provides precise steering, excellent maneuverability and a short turning radius. Volvo's superior system delivers powerful and accurate steering, ensuring outstanding machine control and highly productive, safe operation.



## Maintenance free rotating hitch

For high uptime and low operating costs, the 100% maintenance free, sealed hitch, features permanently greased tapered roller bearings. It allows independent movement of the tractor and trailer without frame twist, while providing oscillation for good ground contact in rough conditions.



## Durable frames

Heavy-duty, rigid front and rear frames have been designed for severe off-road operations and long life-span. The robust Volvo design is utilizing robotic welding for ultimate quality and durability.



#### **Articulation and oscillation joint**

The connection between the tractor and the trailer unit has high ground clearance, industry-leading hydro-mechanical steering and a maintenance free rotating hitch design. This combination boosts accessibility and drivability in severe conditions and maximizes uptime.

# Adding value to your business.

Being a Volvo customer means having a complete set of services at your fingertips. Volvo can offer you a long-term partnership, protect your revenue and provide a full range of customer solutions using high quality parts, delivered by passionate people. Volvo is committed to increasing the positive return on your investment and maximising uptime.



**Complete Solutions**

Volvo has the right solution for you. So why not let us provide all your needs throughout the whole life cycle of your machine? By listening to your requirements, we can reduce your total cost of ownership and increase your revenue.



**Genuine Volvo Parts**

Our attention to detail is what makes us stand out. This proven concept acts as a solid investment in your machine's future. Parts are extensively tested and approved because every part is vital for uptime and performance. Only by using Genuine Volvo Parts, can you be sure that your machine retains the renowned Volvo quality.

**Service Network**

In order to respond to your needs faster, a Volvo expert is on the way to your job site from one of our Volvo facilities. With our extensive infrastructure of technicians, workshops and dealers, Volvo has a comprehensive network to fully support you using local knowledge and global experience.





### PROFITABILITY



### SERVICE PLAN

	DAY01	DAY02	DAY03	DAY04	DAY05	DAY06	DAY07
1							✓
2				✓	✓		
3	✓						✓
4			✓			✓	✓
5							
6	✓						
7			✓				

### FUEL CONSUMPTION

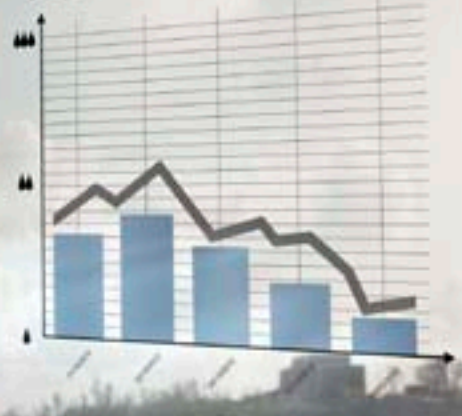

#### Customer Support Agreements

The range of Customer Support Agreements offer preventive maintenance, total repairs and a number of uptime services. Volvo uses the latest technology to monitor machine operation and status, giving you advice to increase your profitability. By having a Customer Support Agreement you are in control of your service costs.



#### Operational data



With vital information at your fingertips, Volvo offers machine owners, operators and service technicians access to a wealth of data that will improve productivity and save money. Enhance operator and owner awareness with fuel efficiency, cycle time and hauler load statistics.

# The key to profitability.

Unlock the secret to hauler productivity with innovations including Volvo's telematics system and diagnostic tools. Volvo gives you access to important information to improve performance and increase machine availability. It all adds up to more with Volvo.

## CareTrack\*

Each Volvo articulated hauler comes standard equipped with CareTrack, the Volvo telematics system. CareTrack provides information for better planning and smarter working; including fuel consumption reports, location reports and service reminders. Save fuel. Reduce costs. Maximise profitability. You can with CareTrack.

\* In markets where CareTrack is available



## Contronics

Contronics continuously provides valuable information on the hauler's systems and operation. Diagnostics and data needed for optimum operation, such as malfunction indicators, are communicated to the operator via a color monitor, which together with a keypad, provide easy navigation between different screens and functions.

## MATRIS

This tool uses information from the machine to analyze and monitor operation. MATRIS analysis supports optimized performance by tracking activity characteristics and identifying opportunities for improvement – resulting in better fuel economy, efficient operation and longer machine life.

# Superior hauling from Volvo.



## Articulation and oscillation joint

The connection between the tractor and the trailer unit has high ground clearance and a maintenance free rotating hitch design.

## Dumping functionality

Volvo's patented, user-friendly load and dump brake technology and tipping lever deliver precise dumping control and faster cycle times.



## Operational data

Volvo offers machine owners, operators and service technicians access to a wealth of vital data that will control productivity and save money.

## CareTrack

Volvo's telematics system guides machine owners towards optimized productivity and their next service – remotely.

## Automatic Traction Control (ATC) and differential locks

Volvo's unique design boasts 100% lockable, no-wear differential locks in 6x4 and 6x6 drive combinations, ensuring excellent rimpull at all times.

## Wet brakes

Oil-cooled, wet, multiple disc brakes on all three axles deliver industry-leading braking performance and low operating costs – even on the muddiest and dustiest sites.





#### **Volvo Care Cab**

The centrally positioned operator station features ergonomically positioned controls, all-around visibility and low internal noise levels for high productivity throughout the shift.

#### **Hydro-mechanical steering**

Unique, self-compensating, hydro-mechanical system provides precise steering, excellent maneuverability and directional stability at high speeds.



#### **Service access**

The front grill swings down, acting as a service platform with anti-slip steps. There is full, safe access to the engine compartment via the 90 degree tilting hood.

#### **Volvo engine**

The new, powerful Stage IV/ Tier 4f Volvo engine delivers the ultimate combination of high performance and high fuel efficiency.



#### **Volvo drivetrain**

The ideally-matched, all-Volvo drivetrain with unique high-ground clearance inline dropbox, has been purpose built for articulated haulers ensuring perfect harmony and optimized performance.



#### **Volvo Care Cab**

The centrally positioned operator station features ideally placed pedals, controls and switches and all-around visibility from a wide front windshield, full-glass door, sloping hood and large rear-view mirrors. With effective sound insulation, the spacious ROPS/FOPS cab has low internal noise levels for high productivity throughout the shift.

At Volvo we know that increased operator comfort reduces fatigue and improves productivity. That's why our industry-leading cab has been designed with the operator in focus – providing a spacious, comfortable and quiet environment that's perfect for optimizing productivity all day long.

# World-renowned for productivity.

## Dumping functionality

Precise dumping control and faster cycle times are delivered through Volvo's patented, user-friendly load and dump brake technology. Together with the tipping lever – which provides automatic float and body lowering– this facilitates ease of operation and reduced fatigue.

## Safe access

With no threshold to cross, the operator can easily enter and exit the cab through the wide opening door. Anti-slip steps and conveniently placed handrails provide safe entry and exit.



## Climate control system

With more than 98% efficiency, Volvo's air filtration system provides the cleanest operator environment in the industry – even in dusty conditions. The high-capacity heating and ventilation system improves comfort, enhancing productivity. Separate defroster vents keep the windows clear.

## Seat offering

A variety of air-suspended seat combinations offer improved operator comfort. Choose from a two, three-point seatbelt. For maximum comfort, select the optional armrest and head restraint.

# Optimized for uptime.

Volvo articulated haulers have been designed for long service intervals. Safe and easy access to grouped service points allows for fast and effortless maintenance and service checks. Trust Volvo to maintain your uptime.

## Swing-down grill

Grouped engine oil filters are easily accessed via the swing-down front grill. The special valve in the belly plate and a dedicated drainage hose, stored in the front grill, ensure fast oil change without spillage.



## Retardation system

Fully enclosed, wet disc brakes feature an external cooling system that absorbs heat and filters the oil from the brakes even when the machine is at a standstill. This prevents contamination while ensuring low operating costs and long service life.



## Automatic monitoring

For maximum uptime and machine availability, the Contronics system electronically monitors fluid levels, providing deviation warnings and scheduled service reminders. This can also be accessed remotely via CareTrack, Volvo's telematics system.





#### Service access

The front grill swings down, acting as a service platform with anti-slip steps. The hood tilts up to 90 degrees for full and safe access to the engine compartment. This makes reaching service points, changing filters and cleaning the cooling package quicker and easier.

# Volvo A25G, A30G in detail.

## Engine

V-ACT, 11 liter, 6-cylinder in line turbocharged diesel engine with 4 valves per cylinder, overhead camshaft and electronically controlled unit injectors. It has wet replaceable cylinder liners and replaceable valve guides and valve seats. The engine has light EGR (Exhaust Gas Recirculation) and exhaust after treatment with EAT-Muffler (Exhaust After treatment) including SCR (Selective Catalytic Reduction) with an electronically controlled UDS (Urea Dosing System).

Cooling system: High capacity cooling system with power and fuel saving, variable speed hydraulic driven fans.

<b>A25G</b>	Volvo D11L (Tier 4f / Stage IV)	
Max power at	r/s	35,0
SAE J1995 Gross	kW	235
Flywheel power at	r/s	35,0
ISO 9249, SAE J1349 Net	kW	234
Max torque at	r/s	19,2
SAE J1995 Gross	Nm	1 950
ISO 9249, SAE J1349 Net	Nm	1 942
Displacement	l	10,8
<b>A30G</b>	Volvo D11L (Tier 4f / Stage IV)	
Max power at	r/s	35
SAE J1995 Gross	kW	265
Flywheel power at	r/s	35
ISO 9249, SAE J1349 Net	kW	264
Max torque at	r/s	21,7
SAE J1995 Gross	Nm	1 950
ISO 9249, SAE J1349 Net	Nm	1 942
Displacement	l	10,8

## Drivetrain

Torque converter with built-in lock-up function.

Transmission: Volvo PowerTronic planetary fully automatic transmission with 6 forward gears and 2 reverse gears.

Dropbox: Volvo-developed, in-line design with high ground clearance and 100% longitudinal "dog clutch" type differential lock.

Axles: heavy duty, purpose built Volvo design with planetary type hub reductions and 100% "dog clutch" type differential locks.

Automatic traction control system (ATC).

## A25G/A30G

Torque converter	2,37:1
Transmission, Volvo	PT 2116
Dropbox, Volvo	IL1 ATC
Axles, Volvo	AHW56/64

## Electrical System

Cables are enclosed in protective plastic conduits, secured to the frame.

All cables, sockets and pins are identified. Prewired for options.

Connectors meet IP67 standard for water-proofing.

Easy accessed battery disconnect switch.

Halogen lights. Powerful LED lights is optional.

## A25G/A30G

Voltage	V	24 (2x12)
Battery capacity	Ah	2x170
Alternator	kW (A)	2,264 (80)
Starter motor	kW	9,0

### Brake System

Complies with ISO 3450.  
Fully hydraulic brakes with wet discs on all wheels.  
Two independent circuits: one for front axle and one for bogie axles.  
Secondary brake: Dual brake circuits with rechargeable accumulators.  
Parking brake: spring-applied disc brake on the propeller shaft.  
Retarder: Service brake retarder function and Volvo Engine Brake (VEB).

### Steering System

Hydro-mechanical, self compensating design. Two double-acting steering cylinders.  
Steering angle: 3,4 steering wheel turns lock-to-lock,  $\pm 45^\circ$ .  
Steering system, including secondary steering fulfills ISO 5010.

### Chassis

Frames: box type, heavy duty. High strength steel, robot welded.  
Rotating hitch: 100% maintenance free, fully sealed, with permanently greased tapered roller bearings.  
Front suspension: Gas-hydraulic struts. Soft and progressive.  
Independent wheel movement via a 3-point mounting system.  
Rear suspension: 100% maintenance free. Straddle mounted bogie beam. Independent wheel movement via a 3-point mounting system.

### Cab

Mounted on rubber pads. Ergonomically designed. Easy entry and exit. Wide angle forward view.  
Operator centrally positioned above the front axle. Adjustable operators seat with retractable seat belt.  
Tilt/telescopic steering wheel. Ergonomically positioned controls.  
Filtered air. Optional climate control system.  
Operator communication system: Contronics.  
Large color display, user-friendly and easy-to-understand information, all vital machine functions are constantly monitored.  
Instructor seat with seat belt.  
Safety: ROPS/FOPS standards approved according to ISO3471, SAE J1040 / ISO3449, SAE J231.  
Sound level in cab according to ISO 6396: 74 dB(A).  
External sound level\* according to ISO 6395:

<b>A25G*</b>	108 dB(A)
<b>A30G*</b>	109 dB(A)

\* with Noise Reduction Kit

### Hydraulic System

Pumps: Four engine-driven variable displacement piston pumps driven by the flywheel PTO.  
One ground-dependent piston pump mounted on the dropbox for emergency steering.  
Two return oil filters with magnetic cores provide effective oil filtration.  
System max working pressure is 25 MPa.

### Dumping System

Patented Load and Dump Brake.  
Dumping Cylinders: two single stage double acting.

### A25G/A30G

Tipping angle	°	74/70
Tipping time with load	sec	12
Lowering time	sec	10

### Body

Plate thickness:		
Front	mm	8
Sides	mm	12
Bottom	mm	14
Chute	mm	14

### Material: HB400 steel

Yield strength	N/mm <sup>2</sup>	1 000
Tensile strength	N/mm <sup>2</sup>	1 250

### Load Capacity

	A25G	A30G
--	------	------

### Standard Body

Load capacity	kg	24 000	28 000
Body, struck	m <sup>3</sup>	11,7	13,6
Body, heaped 2:1	m <sup>3</sup>	15	17,5

### With overhung tailgate

Body, struck	m <sup>3</sup>	12,1	14
Body, heaped 2:1	m <sup>3</sup>	15,6	18,1

# Specifications.

Refill capacities		
	A25G	A30G
	litre	
Crankcase	35	35
Fuel tank	380	380
Cooling system	64	64
Brake cooling system	37	37
Transmission	40	40
Dropbox	9	9
Axles, front/bogie	32/74	38/78
Hydraulic tank	135	135
DEF/AdBlue	39	39

Speed		
	A25G	A30G
	km/h	
<b>Forward</b>		
1	8	8
2	12	12
3	21	21
4	30	30
5	38	38
6	53	53
<b>Reverse</b>		
1	8	8
2	13	13

Operating weight unloaded		
	A25G	A30G
	kg	
<b>Tires</b>	<b>23,5R25*</b>	<b>750/65R25**</b>
Front	13 000	13 100
Rear	9 500	10 500
Total	22 500	23 600
Payload	24 000	28 000

Total weight		
	A25G	A30G
	kg	
<b>Tires</b>	<b>23,5R25*</b>	<b>750/65R25**</b>
Front	15 000	15 600
Rear	31 500	36 000
Total	46 500	51 600

Operating weight includes all fluids and operator

\*) A25G with tires 750/65R25, add 200 kg/axle    \*\*) A30G with tires 23,5R25, decrease 200 kg/axle

Ground Pressure				
	A25G		A30G	
<b>Tires</b>	<b>23,5R25</b>	<b>750/65R25</b>	<b>750/65R25</b>	<b>23,5R25</b>
	kPa			
<b>Unloaded</b>				
Front	132	110	111	133
Rear	48	40	44	53
<b>Loaded</b>				
Front	152	127	132	158
Rear	159	133	153	182

Pos	A25G	A30G
	mm	
A	10 218	10 296
A <sub>1</sub>	4 954	4 954
A <sub>2</sub>	5 736	5 811
B	5 153	5 342
C	3 451	3 451
C <sub>1</sub>	3 318	3 318
C <sub>2</sub>	1 772	1 772
D	2 763	2 762
D <sub>1</sub>	2 606	2 607
E	1 209	1 209
F	4 175	4 175
G	1 670	1 670
H	1 610	1 688
I	609	608
J	2 760	2 834
K	2 103	2 181
L	677	686
L	6 529	6 560
N	8 091	8 092
N <sub>1</sub>	4 065	4 023
O	2 700	2 900
P	2 490	2 690
Q	2 298	2 472
R	513	514
R <sub>1</sub>	629	630
S	2 110	2 293
T	3 083	3 158
U	3 249	3 301
V	2 258	2 216
V*	2 216	2 258
W	2 859	2 941
W*	2 941	2 859
X	458	456
X <sub>1</sub>	586	585
X <sub>2</sub>	659	659
Y	2 258	2 216
Y*	2 216	2 258
Z	2 859	2 941
Z*	2 941	2 859
a <sub>1</sub>	23.5°	23.2°
a <sub>2</sub>	74°	70°
a <sub>3</sub>	45°	45°

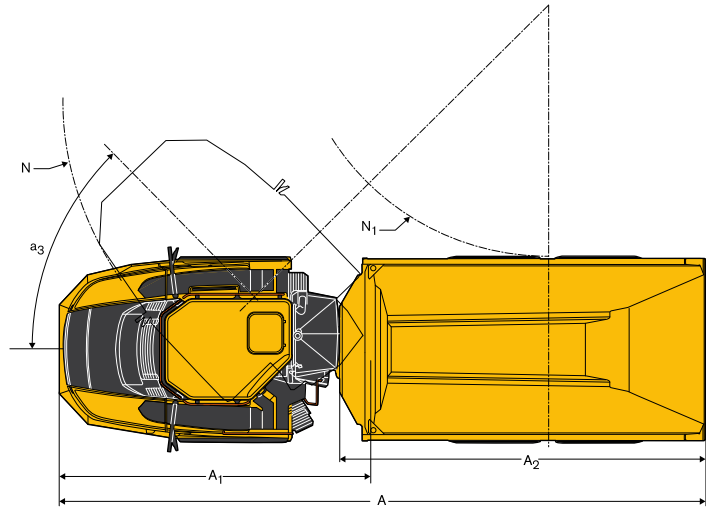
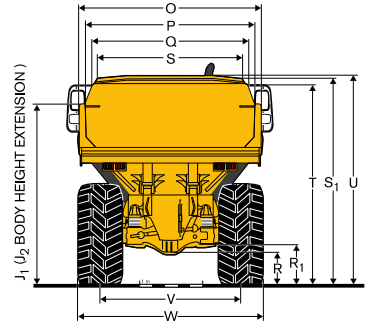
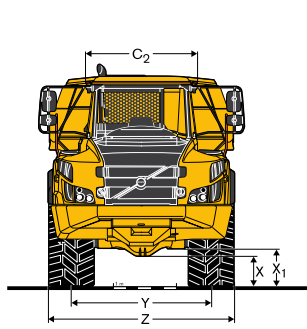
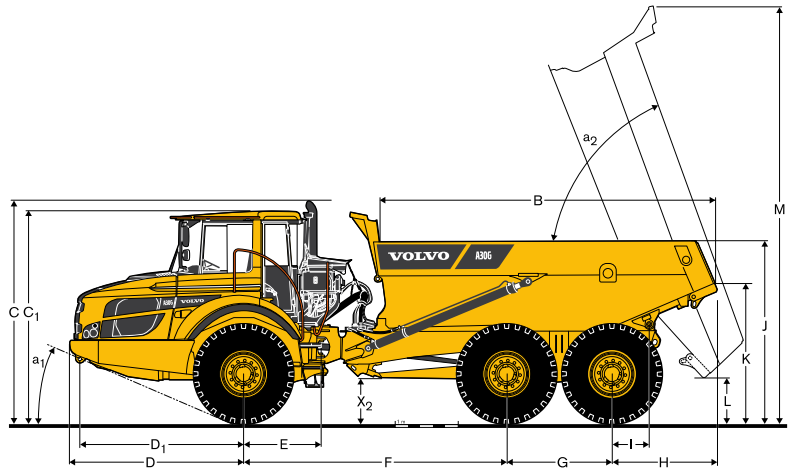

A25G: Unloaded machine with 23.5 R25  
A30G: Unloaded machine with 750/65R25  
\*) A25G with optional 750/65R25 tires;  
A30G with optional 23.5 R25 tires.

# Equipment.

## STANDARD EQUIPMENT

	A25G	A30G
<b>Safety</b>		
Anti-slip steps and platforms	•	•
Dump body lock	•	•
Handrails on steps and platforms	•	•
Hazard lights	•	•
Horn	•	•
Protective grill for cab rear window	•	•
Rear-view mirrors	•	•
Retractable 3-inch safety belt	•	•
ROPS/ FOPS protected Care Cab	•	•
Secondary steering	•	•
Steering joint lock	•	•
Windshield washers	•	•
Windshield wipers with interval function	•	•
<b>Drivetrain</b>		
6x4 and 6x6 automatically engaged drive modes	•	•
Dog clutch type 100% diff-locks in all axles	•	•
Full automatic transmission	•	•
Single stage dropbox with longitudinal diff-lock	•	•
Torque converter with automatic lock-up	•	•
<b>Engine</b>		
Direct injected, electronically controlled, turbocharged, intercooled	•	•
Grouped oil filters, for ease of change	•	•
Preheater for easier cold starts	•	•
Remote oil drain valve and hose for easy access	•	•
VEB (exhaust retarder EPG + compression brake)	•	•
<b>Electrical system</b>		
80 A alternator	•	•
Battery disconnect switch	•	•
Extra 24 V socket for lunch cooler	•	•
<b>Lights:</b>		
Back-up light	•	•
Brake lights	•	•
Cab lighting	•	•
Direction indicators	•	•
Headlights	•	•
Instrument lighting	•	•
Parking lights	•	•
Rear lights	•	•
<b>Brake system</b>		
Load & Dump Brake	•	•
Parking brake on propeller shaft	•	•
Two circuit, fully hydraulic, wet discs on all axles	•	•

	A25G	A30G
<b>Comfort</b>		
Ashtray	•	•
Cab heater with filtered fresh air and defroster	•	•
Can holder /storage tray	•	•
Cigarette lighter	•	•
Instructor seat with seat belt	•	•
Overhead console for radio	•	•
Sliding window	•	•
Space for lunch cooler	•	•
Storage box	•	•
Sun visor	•	•
Tilt/telescopic steering wheel	•	•
Tinted glass	•	•
<b>Operator information interface</b>		
<b>Gauges:</b>		
Brake pressure	•	•
Fuel	•	•
Speedometer	•	•
Tachometer	•	•
Wet disc brakes cooling oil temperature	•	•
<b>Warning lights grouped and easy to read</b>		
Central warning (3 levels) for all vital functions	•	•
<b>Central positioned information display:</b>		
Automatic pre-start checks	•	•
Clock	•	•
Hour meter	•	•
Operational information, easy-to-navigate menu	•	•
Troubleshooting diagnostics	•	•
<b>Body</b>		
Body prepared for exhaust heating and optional equipment	•	•
<b>Exterior</b>		
Front mudguard wideners and rear mudflaps	•	•
<b>Tires</b>		
23.5R25	•	
750/65R25		•
<b>Service and maintenance</b>		
Drainage hose stored in the front grill	•	•
Machine Tracking Information System MATRIS	•	•
Service platform integrated in the front grill	•	•
Tool box	•	•

## OPTIONAL EQUIPMENT

	A25G	A30G
<b>Safety</b>		
Fire-extinguisher and first aid kit	•	•
Warning triangle	•	•
<b>Engine</b>		
Air pre-cleaner, cyclone type	•	•
Air pre-cleaner, heavy-duty, dry type EON	•	•
Electric engine heater (120V or 240V)	•	•
Engine automatic shutdown	•	•
Engine shutdown timer	•	•
External emergency engine stop	•	•
High engine idle speed	•	•
<b>Electrical system</b>		
Anti-theft system (prevents engine start)	•	•
Rear vision system, colour LCD monitor in the cab	•	•
Reverse alarm	•	•
Rotating warning beacon, collapsible mount	•	•
Working lights, front and rear	•	•
<b>Cab</b>		
Air suspended, heated, fully adjustable seat	•	•
Armrest for operator seat	•	•
Cable kit for cab heater (120V or 240V)	•	•
Electrically heated and adjustable rear view mirrors	•	•
Electronic Climate Control (ECC)	•	•
Head restraint for operator seat	•	•
HEPA cab air filter	•	•
Radio installation kit, including loudspeakers	•	•
Radio with CD player	•	•
<b>Body</b>		
Exhaust heating	•	•
Extra front spillguard, bolt-on	•	•
Light material extension, bolt-on kit	•	•
Overhung tailgate, wire or linkage operated	•	•
Side extensions 200 mm (8"), welded	•	•
Underhung tailgate, linkage operated	•	•
Wear plates for heavy duty applications	•	•
<b>Tires</b>		
750/65R25	•	
23.5R25		•
<b>Service and maintenance</b>		
Automatic lubrication system	•	•
Electrical hood opening	•	•
Tool kit with tire inflation unit	•	•
<b>Other</b>		
Arctic kit	•	•
Lifting tools, wheel mounted	•	•
Synthetic hydraulic oil (biologically degradable)	•	•
Towing hitch	•	•
CareTrack	•	•

## SELECTION OF VOLVO OPTIONAL EQUIPMENT

Tailgate, overhung, wire-operated



Entrance light



Engine shutdown timer



Grammer seat



Work lights, LED



Headlights, LED





**VOLVO**

Volvo Construction Equipment

[www.volvoce.com](http://www.volvoce.com)